



SmartConvey

# 转弯机选型手册

TURNING CONVEYOR MANUAL



施玛特自动化（上海）有限公司

SMARTCONVEY AUTOMATION(SHANGHAI)CO.,LTD

# 目录

## 企业简介



SmartConvey is an outcome of near 2 decades and 2 generations of experience and development. In the beginning, it started as a workshop to provide machine maintenance of automatic equipment for local beverage and logistics companies such as "Nongfu Spring", "WAHAHA", "CHINA POST", "ZTO EXPRESS", "YT EXPRESS", "J&T" and etc.

Along with the growth of experience in automatic industry, SmartConvey started focusing on the R&D, Design, and Production of Automation&Logistics Equipment, adhering to "Dedication, Concentration, Creation and Refinement" concepts and building "SmartConvey" International Quality.

Today after near to 20 years of experience SmartConvey is known as the best Automation&Logistics Equipment designer in the fields as Medicine, Cakes and Cookies, Car factory, Tires industry, Logistics industry in the East of the country, and among the top 5 in the country.

In 2021, SmartConvey started its International Trade and is ready to provide the best service in logistics and automatic industry for their potential clients from all over the world.

# CONTENTS

## Company Profile

### 转弯皮带输送机

Turning Belt Conveyor

P 1~2

### 链板转弯输送机

Turning Chain Conveyor

P 3~4

### 网链转弯输送机

Turning Modular Belt Conveyor

P 5~6

### 滚筒转弯输送机

Turning Roller Conveyor

P 7~8



## 转弯皮带输送机 Turning Belt Conveyor

■ 主要技术参数参考 The Main Technical Parameters Reference:

|                        | 输送机形式<br>Conveyor Form       | 普通皮带转弯机<br>Turning Belt Conveyor                          | 刀口皮带转弯机<br>Knife-edge Turning Belt Conveyor |
|------------------------|------------------------------|---|---|
| 皮带参数<br>Belt Data      | 皮带材质<br>Belt Material        | PVC, PU   |   |
|                        | 皮带宽度<br>Belt Width(mm)       | $250\text{mm} \leq W \leq 1000\text{mm}$                  | $1000\text{mm} \leq W \leq 1600\text{mm}$   |
| 输送机参数<br>Conveyor Data | 机架材质<br>Frame Material       | 碳钢Carbon Steel/不锈钢材质Stainless Steel 304,316L/铝型材Aluminium |   |
|                        | 输送机宽度<br>Conveyor Width(mm)  | 200 ~ 1700 (其他尺寸可定制 Other to be Customized)               |   |
|                        | 输送机高度<br>Conveyor Height(mm) | 700 (其他尺寸可定制 Other to be Customized)                      |   |
|                        | 转弯半径<br>Turning Radius R(mm) | 250/400/600/900   | 400/600/900/1200                            |
|                        | 速度<br>Speed(m/min)           | $\leq 45$   |   |

注：以上数据均为参考，详细情况请联系项目工程师

Note: The above data are for reference only. For details, please contact the project engineer

■ 特征 Features:

- 转弯皮带输送机带有PVC,PU等多种材质，能耐油，耐腐蚀，防静电。  
Belt Material of PVC,PU etc, oil resistant, corrosion resistant and anti static.
- 输送平稳，物料与输送带没有相对运动，噪音较小，振动低，能有效避免对输送物的破坏。  
Conveying of smooth, no relative movement between material and conveyor belt, low noise, low vibration, which can avoid damage to the conveying material.
- 输送机整体结构简单，易于使用，易于维护。  
Conveyor with simple structure and easy maintenance.

■ 转弯皮带输送机示意图 Schematic Diagram of Curved belt Conveyor:

Turning Belt Conveyor

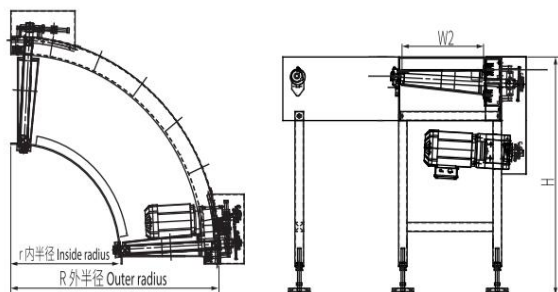

Knife-edge Turning Belt Conveyor

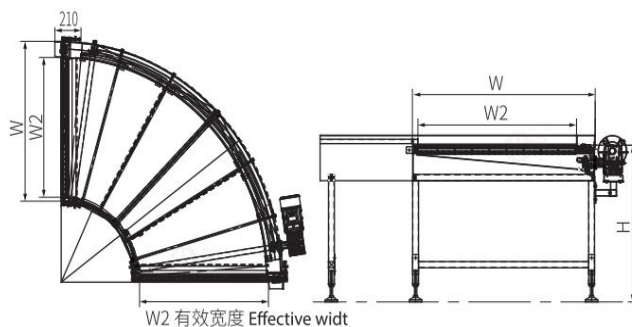

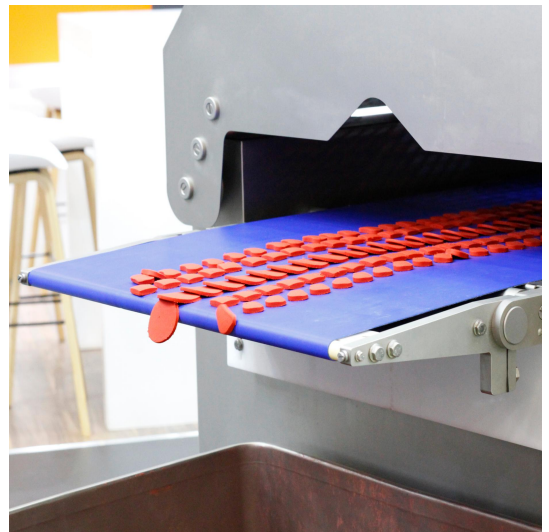
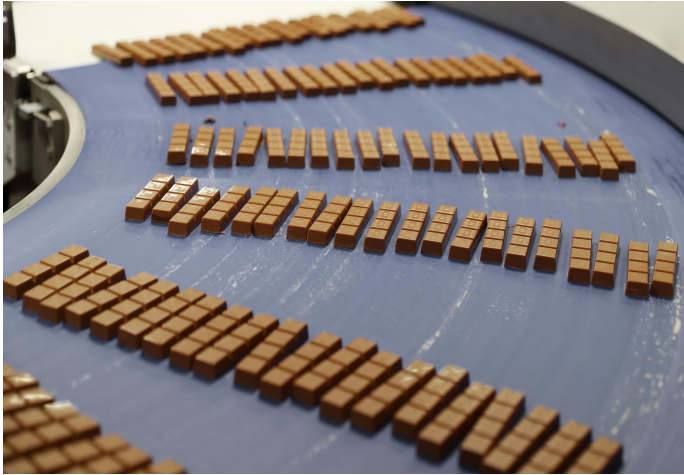



## 链板转弯输送机 Turning Chain Conveyor

### ■ 主要技术参数参考 The Main Technical Parameters Reference:

|                        | 输送机形式<br>Conveyor Form       | 转弯链板输送机<br>Turning Type Chain Conveyor                                     |   |                  |
|------------------------|------------------------------|--|---|------------------|
| 链板参数<br>Chain Data     | 链板类型<br>Chain Type           | 塑料链板, 防滑链板, 不锈钢链板<br>Plastic Chain, Anti-Slip Chain, Stainless Steel Chain |   |                  |
|                        | 链板宽度<br>Chain Width(mm)      | 63.5/82.6/114.3/152.4/190.5/254/304.8                                      |   |                  |
|                        | 链板材质<br>Chain Material       | 塑钢POM, 不锈钢Stainless Steel  |   |                  |
| 输送机参数<br>Conveyor Data | 机架材质<br>Frame Material       | 碳钢烤漆<br>Carbon Steel Baking Paint  | 不锈钢304/316L<br>Stainless Steel 304/316L | 铝型材<br>Aluminium |
|                        | 输送机宽度<br>Conveyor Width(mm)  | 70 ~ 1500 (其他尺寸可定制 Other to be Customized)                                 |   |                  |
|                        | 输送机高度<br>Conveyor Height(mm) | 700 (其他尺寸可定制 Other to be Customized)                                       |   |                  |
|                        | 转弯半径<br>Turning Radius R(mm) | ≥ 610  |   |                  |
|                        | 速度<br>Speed(m/min)           | ≤ 45   |   |                  |

注: 以上数据均为参考, 详细情况请联系项目工程师

Note: The above data are for reference only. For details, please contact the project engineer

### ■ 特征 Features:

- 单列输送多用于饮料贴标, 罐装, 清洗等, 多列输送可满足杀菌机械, 储瓶台, 冷瓶机大量供料的需求。  
Single column conveying is mainly used for beverage labeling, canning, cleaning, etc., multi-column conveying can meet the requirements of sterilization machinery, bottle storage table, cold bottle machine.
- 链板输送面平坦光滑, 输送平稳, 摩擦力小, 结构简单, 可靠性高, 维护方便。  
Surface of chain plate is flat and smooth, conveying is stable, friction is small, structure is simple, reliability is high and maintenance is convenient.

### ■ 转弯链板输送机示意图 Schematic Diagram of Curved belt Conveyor:

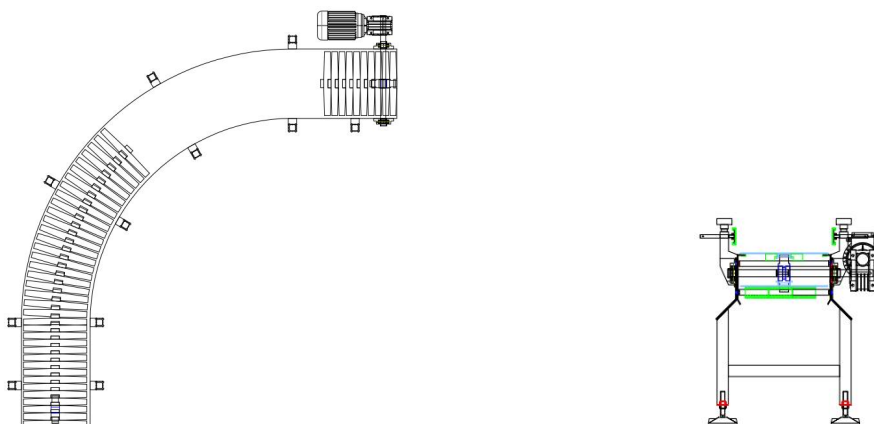

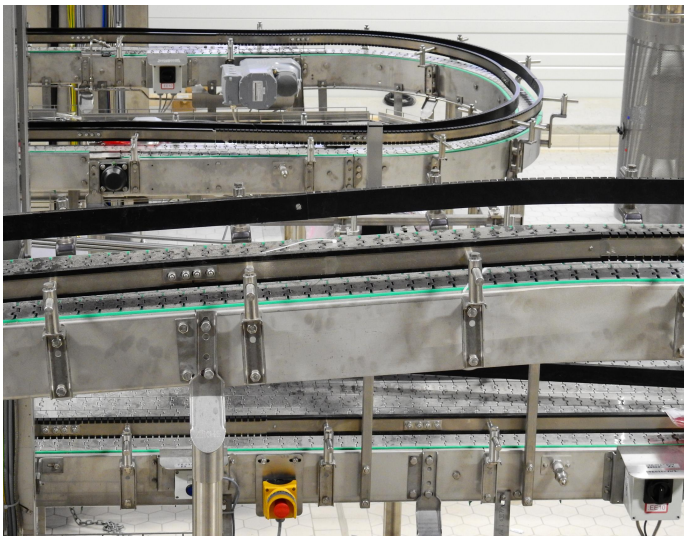



## 网链转弯输送机 Turning Modular Belt Conveyor

■ 主要技术参数参考 The Main Technical Parameters Reference:

|                        | 输送机形式<br>Conveyor Form       | 转弯网链输送机<br>Turning Type Modular Belt Conveyor  |   |                  |
|------------------------|------------------------------|--|---|------------------|
| 网链参数<br>Belt Data      | 网链类型<br>Belt Type            | 平板网带, 平格网带, 凸肋网带, 滚珠网带<br>Flat Type Belt, Flush Gride Belt, Ribbed Belt, Bead Top Belt |   |                  |
|                        | 网链宽度<br>Belt Width(mm)       | 304.8 - 1500   |   |                  |
|                        | 网链材质<br>Belt Material        | 聚甲醛 POM, 聚乙烯 PP, 聚丙烯 PE, 不锈钢 Stainless Steel   |   |                  |
| 输送机参数<br>Conveyor Data | 机架材质<br>Frame Material       | 碳钢烤漆<br>Carbon Steel Baking Paint  | 不锈钢304/316L<br>Stainless Steel 304/316L | 铝型材<br>Aluminium |
|                        | 输送机宽度<br>Conveyor Width(mm)  | 350 ~ 1200 (其他尺寸可定制 Other to be Customized)  |   |                  |
|                        | 输送机高度<br>Conveyor Height(mm) | 800 (其他尺寸可定制 Other to be Customized)   |   |                  |
|                        | 转弯半径<br>Turning Radius R(mm) | $\geq 2.2 * W$   |   |                  |
|                        | 速度<br>Speed(m/min)           | $\leq 45$  |   |                  |

注: 以上数据均为参考, 详细情况请联系项目工程师

Note: The above data are for reference only. For details, please contact the project engineer

■ 特征 Features:

- 设备布局灵活, 可根据输送产品选取不同类型的网链, 来完成水平, 转弯, 倾斜等输送。  
Flexible equipment layout, according to the delivery of products to choose different types of network chain, to complete the horizontal, turn, tilt and other transport.
- 模块化设计, 模具化部件, 组装方便, 维护方便, 输送能力较大。  
Modular design, moulded parts, easy assembly, easy maintenance, large conveying capacity.

■ 转弯网链输送机示意图 Schematic Diagram of Curved belt Conveyor:

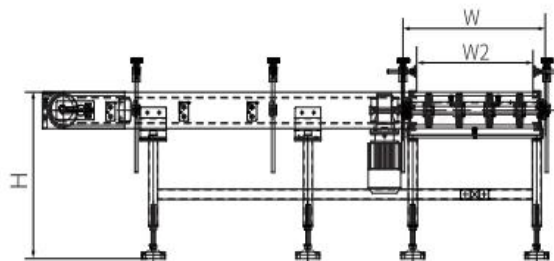
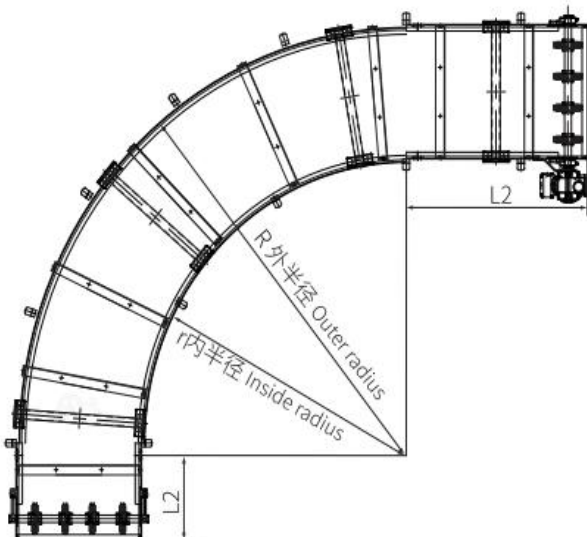



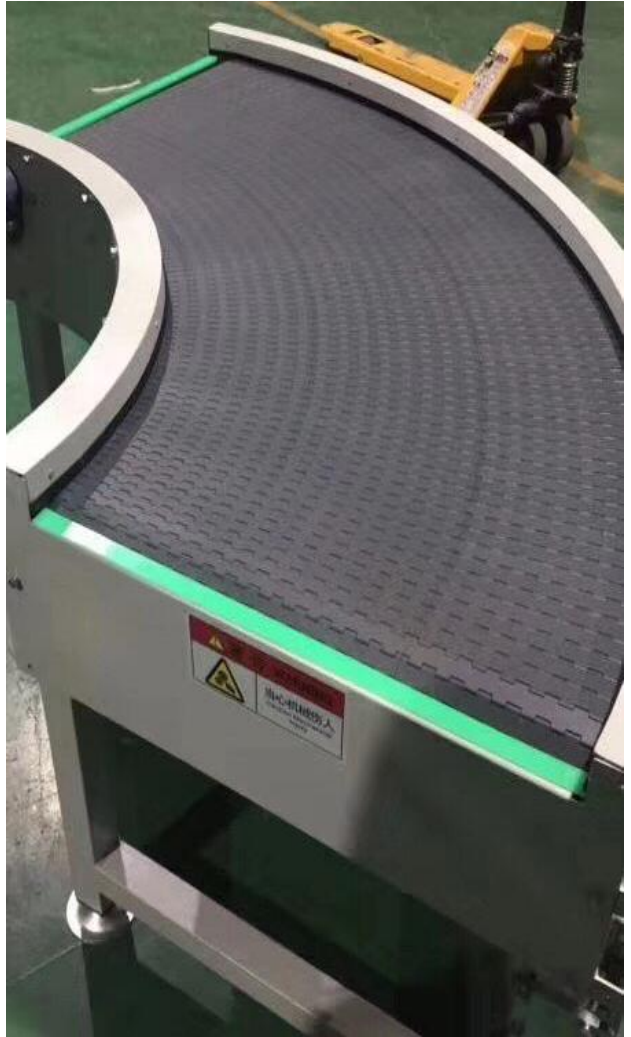



## 滚筒转弯输送机 Turning Roller Conveyor

■ 主要技术参数参考 The Main Technical Parameters Reference:

|                        | 输送机形式<br>Conveyor Form           | 转弯滚筒输送机<br>Turning Type Roller Conveyor     |   |
|------------------------|----------------------------------|---|---|
| 滚筒参数<br>Roller Data    | 滚筒有效宽度<br>Valid Roller Width(mm) | 300, 350, 400, 500, 600, 1000               |   |
|                        | 滚筒材质<br>Roller Material          | 管体<br>Roller Tube                           | 镀锌管 Galvanized CA, 不锈钢 Stainless Steel      |
|                        |                                  | 链齿轮<br>Sprocket                             | 碳钢 Carbon Steel, 塑料 Plastic (配套直径50mm的动力滚筒) |
| 输送机参数<br>Conveyor Data | 机架材质<br>Frame Material           | 碳钢烤漆<br>Carbon Steel Baking Paint           | 不锈钢304/316L<br>Stainless Steel 304/316L     |
|                        | 输送机宽度<br>Conveyor Width(mm)      | 400 ~ 1200 (其他尺寸可定制 Other to be Customized) |   |
|                        | 输送机高度<br>Conveyor Height(mm)     | ≥ 500 (其他尺寸可定制 Other to be Customized)      |   |
|                        | 转弯半径<br>Turning Radius r(mm)     | 400, 600, 800                               |   |
|                        | 速度<br>Speed(m/min)               | ≤ 30  |   |
|                        | 输送方向<br>Travel Direction         | 顺时针R, 逆时针L                                  |   |

注：以上数据均为参考，详细情况请联系项目工程师

Note: The above data are for reference only. For details, please contact the project engineer

■ 特征 Features:

- 设备布局灵活，可根据输送产品选取不同类型的网链，来完成水平，转弯，倾斜等输送。  
Flexible equipment layout, according to the delivery of products to choose different types of network chain, to complete the horizontal, turn, tilt and other transport.
- 模块化设计，模具化部件，组装方便，维护方便，输送能力较大。  
Modular design, moulded parts, easy assembly, easy maintenance, large conveying capacity.

■ 转弯网链输送机示意图 Schematic Diagram of Curved belt Conveyor:

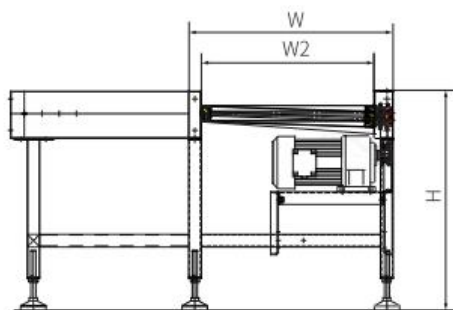
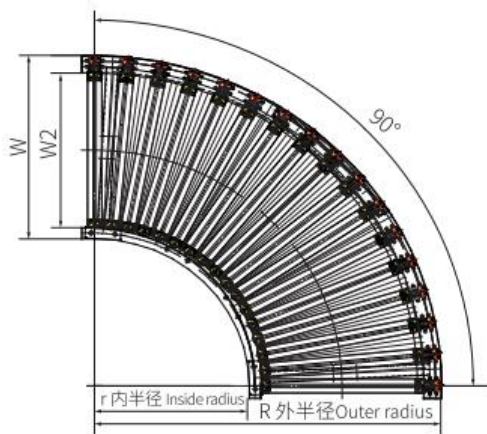

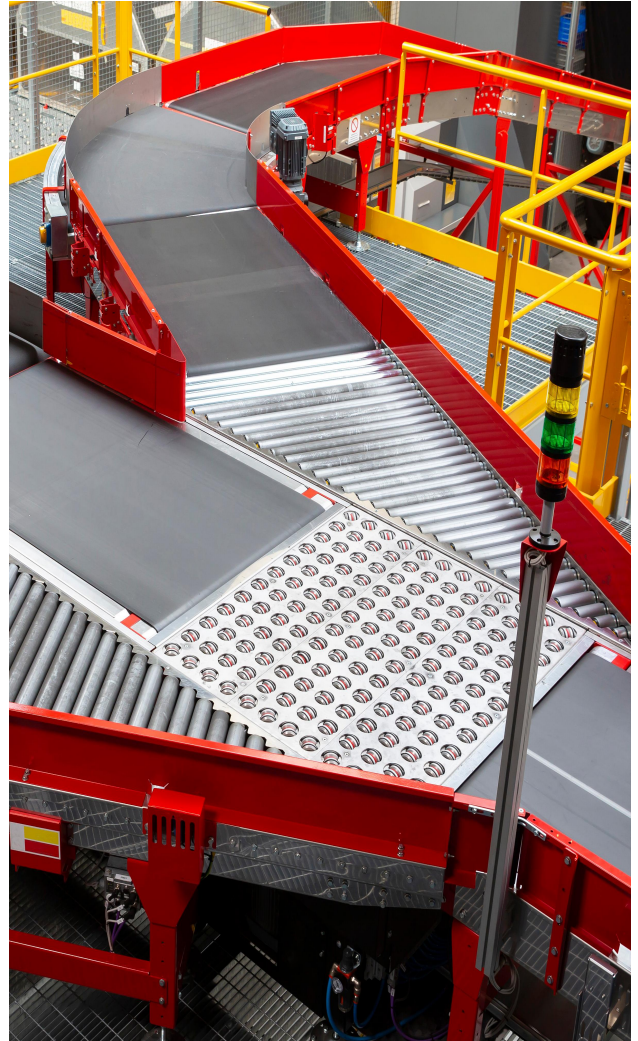



SmartConvey

**施 玛 特 自 动 化 （ 上 海 ） 有 限 公 司**

**SMARTCONVEY AUTOMATION (SHANGHAI) CO., LTD**

Tel: 021-67756716

Web: [www.smartconvey.com](http://www.smartconvey.com)  
[www.smart-conveyor.com](http://www.smart-conveyor.com)

Add: Rm 117, Building 1, No. 655, GaoJi Rd, Songjiang Dist,  
Shanghai,China. (Zip: 201601)